

# **Übersetzungen von DIN-Normen**

## **Manuskriptübersetzungen**

Die in Kopie beigefügte Rohübersetzung wurde vom DIN-Sprachendienst nicht auf ihre Richtigkeit geprüft. Deshalb schließt das Deutsche Institut für Normung e. V. (DIN) ausdrücklich jegliche Haftung für deren Richtigkeit bzw. Vollständigkeit aus.

Jede Art der Vervielfältigung, auch auszugsweise, ist nur mit Genehmigung des DIN Deutsches Institut für Normung e. V., Berlin, gestattet.

# **Translations of DIN-Standards**

## **Typescript translations**

The attached typescript translation has not been checked by DIN-Sprachendienst for its accuracy. Deutsches Institut für Normung e. V. (DIN) cannot, therefore, assume responsibility for its correctness or completeness. On no account shall the translation be considered authorized by DIN. No part of this document may be reproduced without the prior permission of DIN Deutsches Institut für Normung e. V., Berlin.

This page is intentionally blank.

BSI Language Services

TRANSLATION

DIN 15 185

Part 1

Warehousesystems with guided  
industrial trucks; Requirements  
on the ground, the warehouse  
and other requirements

*original language version*

Lagersysteme mit leitliniengeführten  
Flurförderzeugen

Anforderungen an Boden, Regal und sonstige Anforderungen

---

*issued by*

DEUTSCHES INSTITUT FÜR NORMUNG  
Postfach 1107  
Berlin 30  
Germany

---

BSI Language Services has taken all reasonable measures to ensure the accuracy of this translation but regrets that no responsibility can be accepted for any error, omission or inaccuracy.

In cases of doubt or dispute, the original language text only is valid.

© BSI Language Services  
British Standards Institution  
Linford Wood, Milton Keynes. MK14 6LE  
Tel: (0908) 220022 Telex: 825777  
Facsimile: (0908) 320856



	Warehouse systems with guided industrial trucks Requirements for flooring, racking and other requirements	DIN 15 185 Part 1
--	---	-------------------------

All dimensions in mm

Contents	Page
<b>1</b> <b>Field of application</b>	<b>1</b>
<b>2</b> <b>Purpose</b>	<b>1</b>
<b>3</b> <b>Requirements</b>	<b>1</b>
3.1    Flooring	1
3.1.1    General	1
3.1.2    Load-bearing foundation	1
3.1.3    Screed floor	1
3.2    Racking	5
3.2.1    Clearances	5
3.2.2    Tolerances	5
3.3    Other requirements	7
3.3.1    Guiding systems	7
3.3.1.1    Mechanical guiding	7
3.3.1.2    Inductive guiding	7
3.3.2    Centering and transfer stations	7
3.3.3    Racking front clearance	7

## **1    Field of application**

This Standard applies to the use of guided industrial trucks in warehousing systems.

## **2    Purpose**

This Standard specifies the requirements for flooring, racking, guiding systems and transfer equipment used for servicing high-rack bay storage using guided industrial trucks as part of a warehousing system.

## **3    Requirements**

The requirements for the functional components

- flooring
- racking
- guiding systems
- transfer equipment

should be selected such as to ensure the operating safety of the overall warehousing system.

### **3.1 Flooring**

#### **3.1.1 General**

The floor must be:

- of sufficient strength
- even
- level.

#### **3.1.2 Load-bearing foundation**

The load-bearing foundation must be constructed to conform with the applicable Standards, e.g. DIN 1045, DIN 18 202.

Allowing for all loading stresses, the load-bearing foundation must display a minimum strength equivalent to concrete of quality B 25 as defined by DIN 1045.

Allowing for possible settlement, the load-bearing foundation must be laid to ensure that the permitted angular tolerances as defined by DIN 18 202 are not exceeded.

Manholes, conduits and similar floor obstructions must be positioned at a minimum distance of 200 mm from

- racking gangways
- racking pillars.

Divergences from this rule require special safety measures.

#### **3.1.3 Screed floor**

The screed floor must fulfil the requirements for Stress Class II (average) as stated in Table 1 of DIN 18 560 (currently in draft form).

The floor must not display plastic deformation under load.

The floor must be resistant to oils and grease.

The nature of the screed floor must be such as to permit achievement of the braking distances defined in DIN 15 160 Part 1.

Resistance to earth  $R_E$  must not exceed  $10^6 \Omega$  measured according to DIN 51 953.

Notwithstanding DIN 18 202, the tolerances stated in Tables 1 & 2 below must be complied with in narrow gangways and areas where loads are driven raised; these tolerances apply to the wheel tracks.

Note 1: The stricter tolerance requirements for the screeded traffic surface must be specified and agreed as a primary condition of the contract.

Note 2: The manufacturer of the industrial trucks should be consulted as to the position of the wheel tracks.

**Table 1: Lateral height variations across the tracks**

	Permitted height difference $h$ as maximum value measured between outer wheel tracks $Sp$ at track gauge $S$ in m			
	up to 1.0 m	over 1.0 m to 1.5 m	over 1.5 m to 2.0 m	over 2.0 m to 2.5 m
Industrial truck lifting height $\leq 6.00$ m	2.0	2.5	3.0	3.5
Industrial truck lifting height $> 6.01$ m and automatic operation	1.5	2.0	2.5	3.0

**Table 2: Evenness tolerances on the line of the tracks**

Maximum measured indentation depth in the wheel tracks $Sp$ at measuring intervals in m				
	1.0	2.0	3.0	4.0
For all types of application	2.0	3.0	4.0	5.0
Evenness test procedure: refer to DIN 18 202				

The evenness of the remaining floor area must conform to DIN 18 202/05.86, Table 3, row 3.

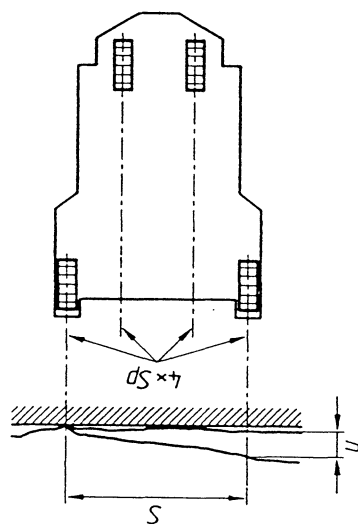

Figure 1: Height difference  $h$ , track gauge  $S$  and wheel tracks  $Sp$

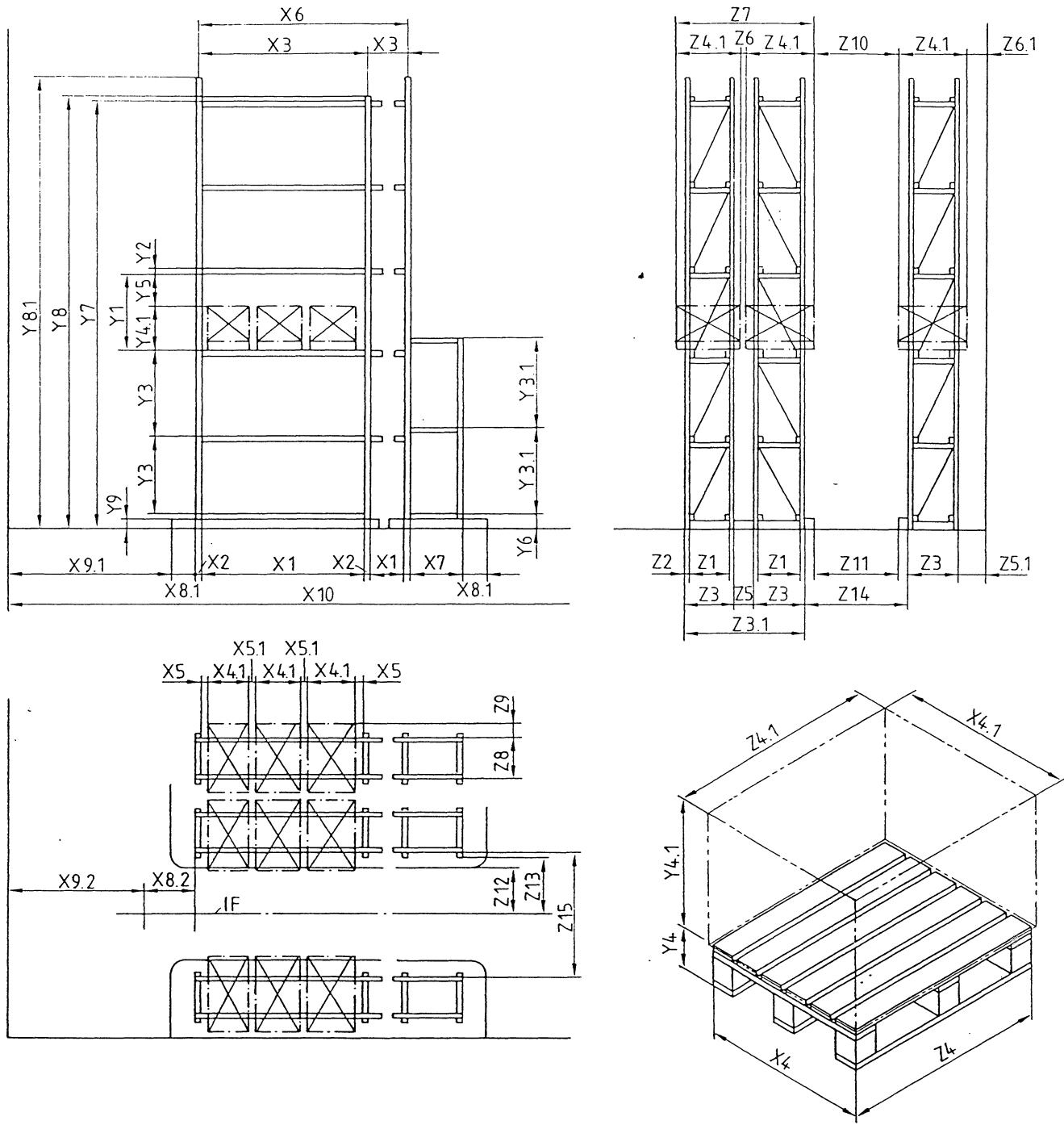

Figure 2: Racking, guide system, load support and load unit; warehousing system dimensions



Captions to the dimensions in Figure 2:

- X 1 Clear drive-in width
  - X 2 Pillar width
  - X 3 Cell width
  - X 4 Width of load support
  - X 4.1 Width of load unit
  - X 5 Clearance between load unit and rack-pillar
  - X 5.1 Clearance between load unit and load unit
  - X 6 Overall rack length ( $n \times X3 - X2$ )
  - X 7 Length of pick-up station
  - X 8.1 Length of mechanical drive-in aide
  - X 8.2 Length of inductive drive-in aide
  - X 9.1 Length of rack front clearance excluding X 8.1
  - X 9.2 Length of rack front clearance excluding X 8.2
  - X 10 Overall length of rack system
- 
- Y 1 Clear cell height
  - Y 2 Height of shelf rest
  - Y 3 Cell height
  - Y 3.1 Cell height of centering or pick-up station
  - Y 4 Height of load support
  - Y 4.1 Height of load unit
  - Y 4.2 Drive-in height
  - Y 5 Clearance to bottom edge of shelf rest
  - Y 6 Height of lowest shelf rest
  - Y 7 Height of highest shelf rest
  - Y 8 Internal pillar height
  - Y 8.1 External pillar height
  - Y 9 Height of mechanical guide system
- 
- Z 1 Clearance between pillars
  - Z 2 Depth of pillar
  - Z 3 Latticework column depth
  - Z 3.1 Latticework column depth - double rack
  - Z 4 Depth of load support
  - Z 4.1 Depth of load unit
  - Z 5 Clearance latticework column to latticework column
  - Z 5.1 Clearance latticework column to structural fittings
  - Z 6 Clearance load unit to load unit
  - Z 6.1 Clearance load unit to structural fittings
  - Z 7 Space above load units in double rack
  - Z 8 Space over shelves
  - Z 9 Projection of load unit over shelf rest
  - Z 10 Clearance between load units in gangway
  - Z 11 Clearance between mechanical guides in gangway
  - Z 12 Distance from gangway centre to mechanical guide

- Z 13 Distance from pillar to inductive guide (gangway centre)
- Z 14 Gangway clearance between pillars
- Z 15 Gangway clearance between shelves

### 3.2 Racking

Figure 2 shows the terminology applied to the various racking, guiding and load unit components required for dimensioning a high-bay storage facility. Component assignment follows the standard XYZ planes used for strength calculations.

#### 3.2.1 Clearances

The following minimum distances are mandatory:

X 5	between load unit and rack pillars	100 mm
X 5.1	between individual load units	100 mm
Y 5	between load units and the bottom edge of the shelf rest	
	- industrial truck lifting height = 6.00 m, with positioning aide, and edge length of load unit = 1.30 m	100 mm
	- in all other cases	150 mm
Z 6	between load units in double bay without push-through stays	100 mm
Z 6.1	between load unit and structural fittings (eg sprinklers, binders, cabling)	100 mm

The fork opening on all load supports must as a minimum conform to DIN 15 141 Part 1 in the Y plane.

#### 3.2.2 Tolerances

The tolerances required to ensure the functional safety of the racking structure are assigned to 2 classes depending on the mode of operation:

Racking Class 1      Industrial truck lifting height < 6.01 m, positioning device, automatic operation

Racking Class 2      Industrial truck lifting height ≤ 6.00 m, no positioning device

The applicable tolerances are printed in Table 3. The tolerances should be measured at the positions indicated in Figure 3.

**Table 3: Racking structural tolerances**

Tolerance	Description of tolerance	Racking Class	
		1 (> 6.01 m)	2 (≤ 6.00 m)
A	Divergence per cell width	± 3	± 3
At	Cumulative divergence over rack length by cell width	± 2	± 2
B	Difference on length dimension between opposite pillars; cumulative value of all length variances $B-B_n$	± 2 max 10	± 5 max 10
C	Deviation of pillars from the vertical in X and Z planes	1/750 x height	1/350 x height
D	Depth of pillars (single or double bay)	± 5	± 5
E	Variation in width of gangway	± 5	± 10
EFÜ	Distance between the mechanical guides - over entire length	+ 5 0	+ 5 0
	- over 1 m	+ 2 0	+ 2 0
F	Divergence of gangway from centre line (over 20 m)	± 5	± 5
G	Divergence of the inductive guide from centre line over entire length	± 5	± 5
I	Bowing of pillars relative to their own axis between the impact points of strengthening plates	1/500 x height	1/400 x height
K	Divergence of the bottom shelf rest to the screed floor	± 2.5	± 5
$K_1-K_n$	Divergence of the bottom shelf rest to all other shelf rests, plus the differences between the latter (expressed as the difference of $K_n-K_{n-1}$ )	± 5	± 5
$K_{max}$	Divergence of the topmost shelf rest to the screed floor	± 7.5	± 10
L	Deviation between the shelf rests in the same bay in the Y dimension	3 up to 1/3000 x height	5 up to 1/2000 x height
M	Divergence in height between the mechanical guide and the screed floor over entire length	± 5	± 5
N	Buckling of the shelf rest	max 10	1/200 x length

Note: *K* refers to the tolerance deviation within each horizontal storage level, normally that of a single shelf rest within a row.

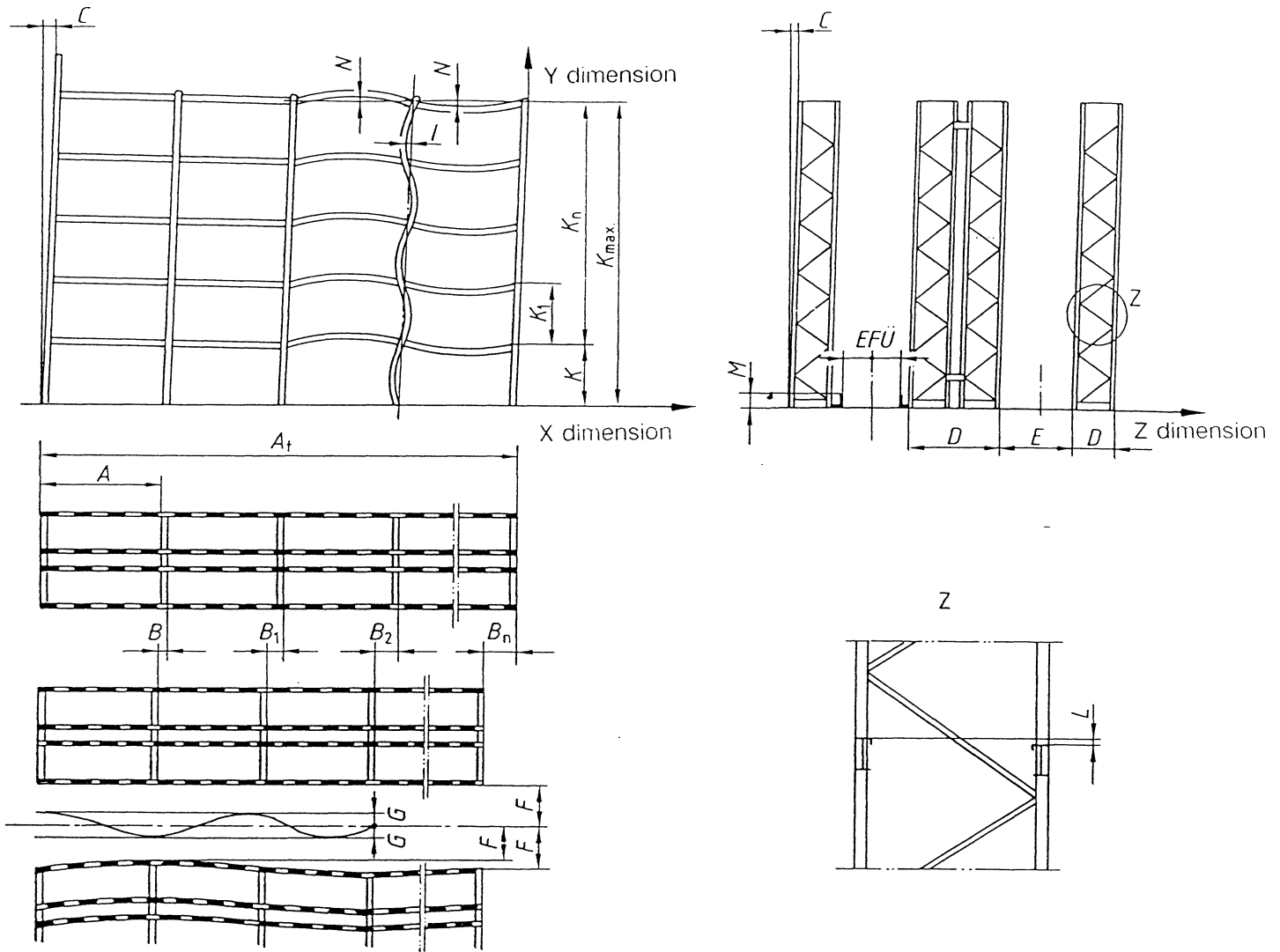

Figure 3: Tolerance data

### 3.3 Other requirements

#### 3.3.1 Guiding systems

The requirements for guiding systems imposed by sections 3.3.1.1 and 3.3.1.2 also apply subject to adaptation to other guidance systems such as, for instance, laser guiding, coordinate grids and track marking systems.

##### 3.3.1.1 Mechanical guiding

The guiding elements of mechanical systems must be free from any irregularities on the paths of the guide rollers which could impair the smooth running of the industrial trucks. Guiding elements must be laid to an accuracy within the tolerances specified in Table 3.

### **Cited Standards**

DIN 1045	Reinforced concrete structures; design and construction
DIN 15 141 Part 1	Transportation chain; pallets; types and principal dimensions of flat pallets
DIN 18 202	Tolerances in building; buildings
DIN 18 560 Part 7	(currently in draft form) Screeds in building; testing the drain-off capacity for electrostatic discharges of flooring materials in explosion-risk enclosed spaces
DIN 51 953	Testing of organic floor coverings; testing of ability of floor coverings in room with explosion hazard to dissipate electrostatic charges.

### **Other relevant Standards**

DIN 15 184	Powered industrial trucks; powered industrial trucks for servicing high-bay storage; safety requirements and testing
DIN 15 185 part 2	(currently in draft form) Warehouse systems with guided industrial trucks; staff safety in the use of industrial trucks in narrow gangways

### **International Patent Classification**

B 65 G 1/00  
B 65 G 43/00  
B 66 F 9/06  
E 04 F 15/00